

DELTA

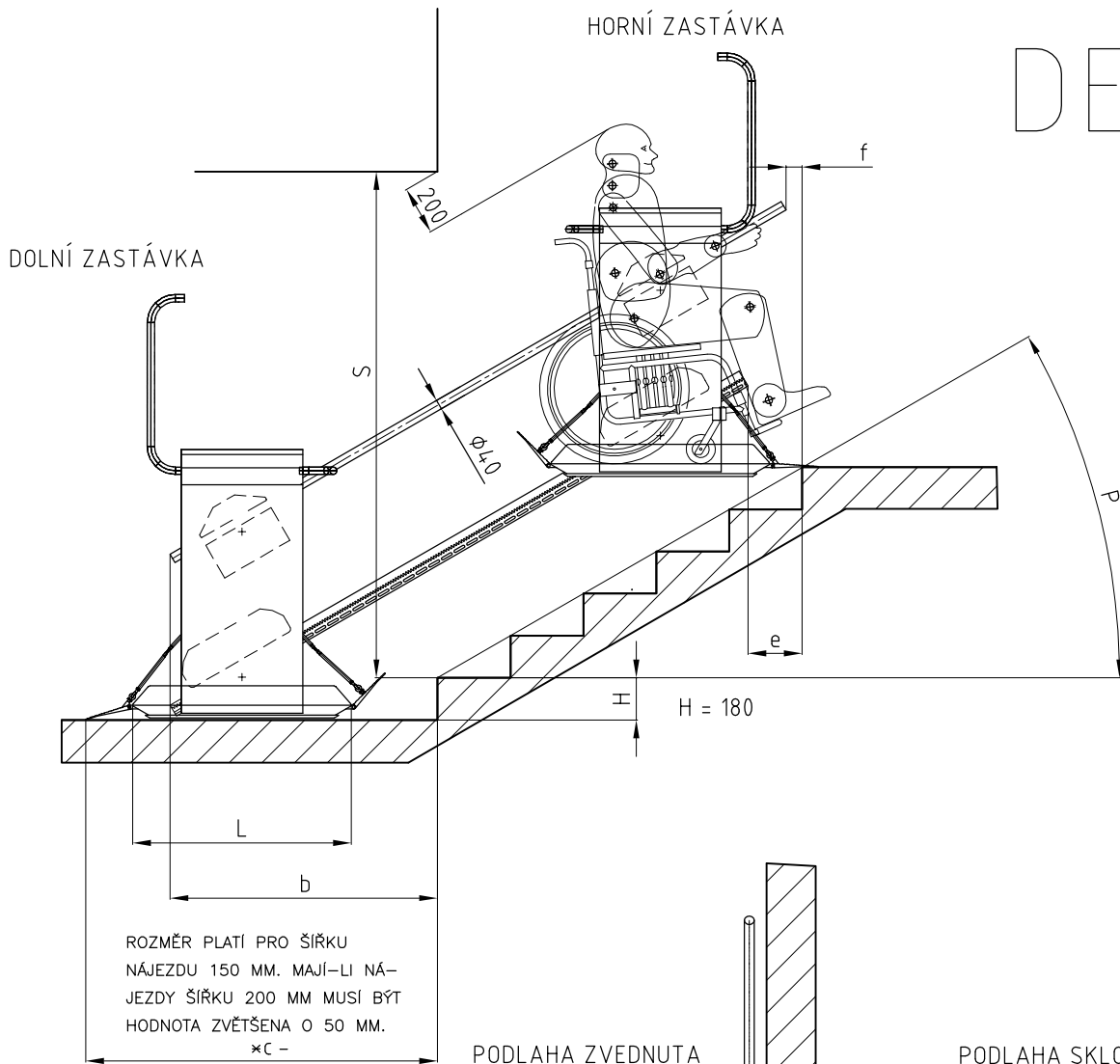

PODLAHA ZVEDNUTA

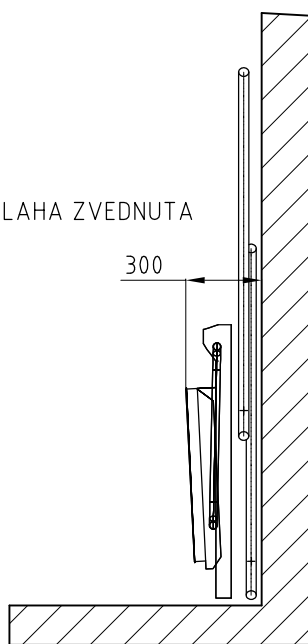

PODLAHA SKLOPENÁ

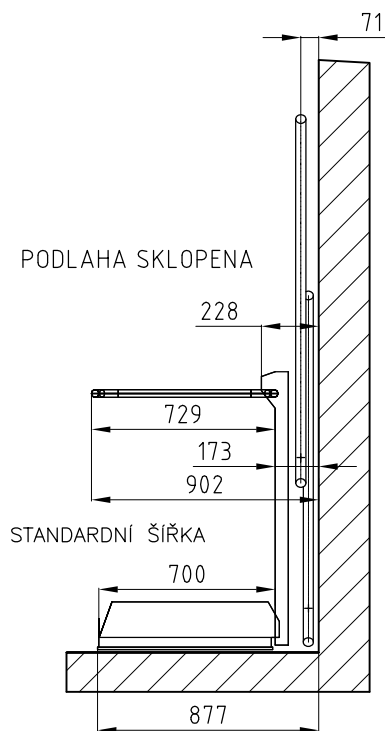

15°	0,5 L + 987	L + 857
20°	0,5 L + 805	L + 657
25°	0,5 L + 695	L + 555
30°	0,5 L + 620	L + 470
35°	0,5 L + 540	L + 420
40°	0,5 L + 515	L + 400
45°	0,5 L + 480	L + 366
P	b	*c
STOUPÁNÍ	L - SPECIÁLNÍ VELIKOST	

15°	1362	1607	-149	35	1810	1437	1757	-229	-45	1815	1487	1857	-302	-118	1855	1612	2107	-440	-255	1910
20°	1180	1407	-135	40	1860	1255	1557	-220	-40	1885	1305	1657	-263	-87	1920	1430	1907	-405	-220	2010
25°	1070	1305	-90	80	1910	1145	1455	-185	-15	1965	1195	1555	-245	-95	1995	1320	1805	-400	-205	2105
30°	995	1220	-95	60	1980	1070	1370	-175	-20	2050	1120	1470	-230	-75	2075	1245	1720	-395	-210	2220
35°	915	1170	-115	30	2070	990	1320	-185	-40	2150	1040	1420	-245	100	2185	1165	1670	-410	-225	2355
40°	890	1150	-135	-5	2180	965	1300	-185	-55	2265	1015	1400	-285	-155	2335	1140	1650	-410	-235	2515
45°	855	1116	-160	-40	2295	930	1266	-230	-110	2400	980	1366	-320	-200	2490	1105	1616	-425	-260	2680
P	b	*c	e	f	S	b	*c	e	f	S	b	*c	e	f	S	b	*c	e	f	S
STOUPÁNÍ	L = 750					L = 900					L = 1000					L = 1250				

Změna rozměrů vyhrazena !